

Since 1980
divspec

an Edwards & West Co.



www.divspec.com

**PREMIUM STRUT
ACCESSORIES**



605 Springfield Rd.

Kenilworth, NJ 07033

Ph: (908) 688-2550 * Fax: (908) 688-9385

4785 Kirk Rd.

Winston-Salem, NC 27103

Ph: (336) 760-0050 * Fax: (336) 760-0580



Edwards & West Inc. t/a Divspec, has been serving the industrial, commercial, manufacturing, institutional & construction trades with fastener products since 1980. We are now extremely proud to introduce you to our quality line of imported strut fittings & clamps. We are the sole United States representative for Flexistrut Pipe Support (Changshu) Co. Ltd. Flexistrut (Changshu) is an ISO Certified manufacturer & a division of Flexistrut Australia.

The fittings displayed in this catalog are a sampling of the products we have available. They are available in a variety of finishes including Zinc Plated Steel, Zinc Dichromate, Zinc Trivalent, 304 Stainless, 316 Stainless, Hot Dipped Galvanized & Powder Coat. Please contact your Divspec Sales Representative for price consideration, product samples and inquiries relative to other products. We offer several programs that can be customized to your specific needs. Direct container shipment & private labeling is also available.

Our prices are extremely competitive & our products are consistent with the quality you expect. If given the opportunity, we won't disappoint you.

Thank you for considering Divspec.



Our commitment to Quality is... “Stainless”

GLOSSARY

1	SPRING NUTS
2	BEAM CLAMPS
3	RIGID CLAMPS
4	EMT-MULTI-GRIP CLAMPS
5	TUBING CLAMPS
6	COPPER TUBING CLAMPS
7	CUSHION CLAMPS TUBE
8	CUSHION CLAMPS PIPE
9-11	FLAT FITTINGS
12-16	ANGLE FITTINGS
17-18	WING FITTINGS
19-21	POST BASES
22	SPLICE CHANNEL
23	GENERAL FITTINGS

SPRING NUTS

Without spring

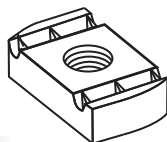

Part Number	Size	Thrd	Thk	Wt./ 100Pcs.
SN025WO	1/4	20	1/4	6
SN037WO	3/8	16	3/8	8
SN050X37WO	1/2	13	3/8	7
SN050WO	1/2	13	1/2	12
SN062WO	5/8	11	1/2	13
SN075WO	3/4	10	1/2	15
SN087WO	7/8	9	1/2	13
SN062X37WO	5/8	11	3/8	10
SN075X37WO	3/4	10	3/8	9
SN031X37WO	5/16	18	3/8	7

Long spring

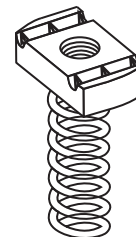

Part Number	Size	Thrd	Thk	Wt./ 100Pcs.
SN025LS	1/4	20	1/4	7
SN037LS	3/8	16	3/8	9
SN050X37LS	1/2	13	3/8	9
SN050LS	1/2	13	1/2	12
SN062LS	5/8	11	7/16	16
SN075LS	3/4	10	7/16	15
SN031LS	5/16	18	3/8	7

Short spring

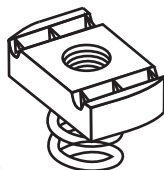

Part Number	Size	Thrd	Thk	Wt./ 100Pcs.
SN025SSP	1/4	20	1/4	7
SN037SSP	3/8	16	3/8	9
SN050X37SSP	1/2	13	3/8	9
SN062X37SSP	5/8	11	3/8	10
SN075X37SSP	3/4	10	3/8	9
SN031X37SSP	5/16	18	3/8	7

Regular spring

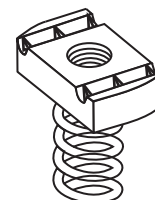

Part Number	Size	Thrd	Thk	Wt./ 100Pcs.
SN025	1/4	20	1/4	7
SN037	3/8	16	3/8	9
SN050X37	1/2	13	3/8	9
SN050	1/2	13	1/2	12
SN062	5/8	11	1/2	16
SN075	3/4	10	1/2	15
SN031X37	5/16	18	3/8	9
SN087	7/8	9	1/2	13

Top spring



Part Number	Size	Thrd	Thk	Wt./ 100Pcs.
TSN025	1/4	20	1/4	6
TSN037	3/8	16	3/8	9
TSN050	1/2	13	3/8	8
TSN031	5/16	18	3/8	9

Also available in stainless

BEAM CLAMPS

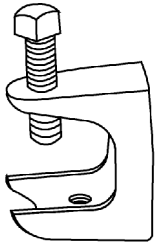

Electrical Beam Clamps

Part Number	Size	Thrd	Wt./ 100Pcs.	Std. Pkg.
KBC101	1/4	20	20	50
KBC103	3/8	16	46	50
KBC104	1/2	13	140	10

Material: Malleable Iron Electro-Galvanized

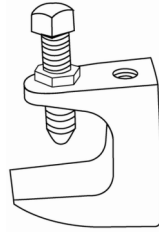

Top Beam Clamps

Part Number	Size	Thrd	Wt./ 100Pcs.	Std. Pkg.
TBC037	3/8	16	30	100
TBC050	1/2	13	52	25
TBC062	5/8	11	70	25
TBC075	3/4	10	98	25

Material: Malleable Iron Plain or Electro-Galvanized
Also available in stainless

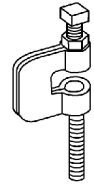

C-Clamps w/Locknut

Part Number	Size	Thrd	Wt./ 100Pcs.	Std. Pkg.
D351L037P	3/8	16	37	50
D351L050P	1/2	13	37	50

Material: Steel

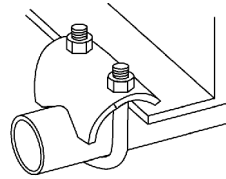

Right Angle Clamps

Part Number	Size	Wt./ 100Pcs.	Std. Pkg.
D422-3/8	3/8	36	25
D422-1/2	1/2	40	25
D422-3/4	3/4	40	25
D422-1	1	44	25
D422-1 1/4	1 1/4	48	25
D422-1 1/2	1 1/2	57	25
D422-2	2	84	25
D422-2 1/2	2 1/2	108	25
D422-3	3	124	25
D422-3 1/2	3 1/2	136	25
D422-4	4	156	25

Material: Malleable Iron Hot Dip Galvanized

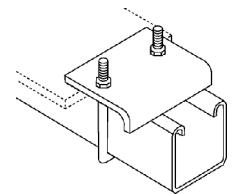

Window Clamp

Part Number	Size	Wt./ 100Pcs.	Std. Pkg.
D441-22	1-5/8	84	25
D441-22A	3-1/4	112	25

Material: Steel Zinc
Also available in stainless

PIPE CLAMPS

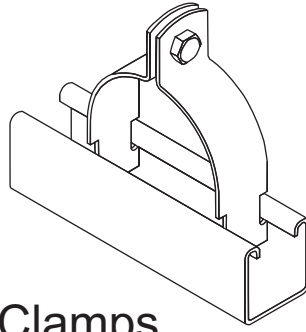

Rigid Conduit Clamps

Part Number	Pipe Size	O.D. Size	Steel Ga.	Wt./ 100Pcs.	Std. Pkg.
R037AS	3/8	.675	16	10	100
R050AS	1/2	.840	16	12	100
R075AS	3/4	1.05	14	15	100
R100AS	1"	1.315	14	18	100
R125AS	1-1/4	1.66	14	23	100
R150AS	1-1/2	1.90	12	30	50
R200AS	2"	2.375	12	34	50
R250AS	2-1/2	2.875	12	38	50
R300AS	3"	3.50	12	44	50
R350AS	3-1/2	4.00	11	48	25
R400AS	4"	4.50	11	52	25
R500AS	5"	5.563	11	64	25
R600AS	6"	6.625	10	84	25
R800AS	8"	8.625	10	116	25
R1000AS	10"	10.75	10	130	25
R1200AS	12"	12-3/4	10	160	10

Also available in stainless and hot dip galvanized

PIPE CLAMPS

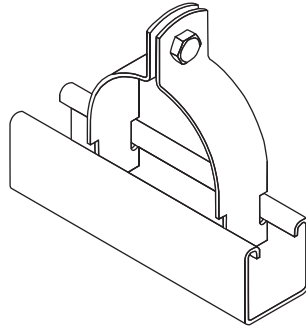

EMT Clamps

Part Number	Nom. Size	O.D. Size	Steel Ga.	Wt. 100Pcs.	Std. Pkg.
E037AS	3/8	.577	16	10	100
E050AS	1/2	.706	16	11	100
E075AS	3/4	.922	16	12	100
E100AS	1"	1.163	14	16	100
E125AS	1-1/4	1.51	14	21	100
E150AS	1-1/2	1.74	12	28	50
E200AS	2"	2.197	12	32	50

Multi-grip Clamps

Part Number	Nom. Size	O.D. Range Min/Max	Wt. 100Pcs.	Std. Pkg.
M037AS	3/8	.557 to .675	9	100
M050AS	1/2	.706 to .840	11	100
M075AS	3/4	.922 to 1.050	16	100
M100AS	1"	1.163 to 1.315	17	100
M125AS	1-1/4	1.510 to 1.660	22	100
M150AS	1-1/2	1.740 to 1.900	30	50
M200AS	2"	2.197 to 2.375	32	50

Also available in stainless and hot dip galvanized

TUBING CLAMPS

Tubing Clamps

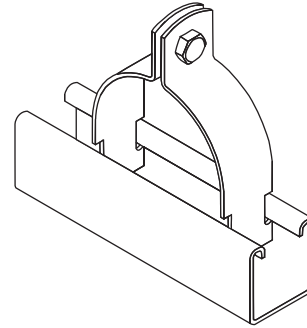

Part Number	O.D. Size	Tube Size	Steel Ga.	Wt. 100Pcs	Std. Pkg.
T025	1/4"	1/8"	16	8	100
T037	3/8"	1/4"	16	8	100
T050	1/2"	3/8"	16	8	100
T062	5/8"	1/2"	16	9	100
T075	3/4"	5/8"	16	11	100
T087	7/8"	3/4"	16	11	100
T100	1"	7/8"	14	13	100
T112	1 1/8"	1"	14	15	100
T125	1 1/4"	1 1/8"	14	16	100
T137	1 3/8"	1 1/4"	14	17	100
T150	1 1/2"	1 3/8"	14	18	100
T162	1 5/8"	1 1/2"	14	19	100
T175	1 3/4"	1 5/8"	12	19	50
T187	1 7/8"	1 3/4"	12	28	50
T200	2"	1 7/8"	12	31	50
T212	2 1/8"	2"	12	31	50
T225	2 1/4"	2 1/8"	12	33	50
T237	2 3/8"	2 1/4"	12	34	50
T250	2 1/2"	2 3/8"	12	35	50
T262	2 5/8"	2 1/2"	12	39	50
T275	2 3/4"	2 5/8"	12	37	50
T287	2 7/8"	2 3/4"	12	39	50
T300	3"	2 7/8"	12	41	50
T312	3 1/8"	3"	12	42	50
T325	3 1/4"	3 1/8"	12	42	50
T337	3 3/8"	3 1/4"	12	43	50
T350	3 1/2"	3 3/8"	12	44	50
T362	3 5/8"	3 1/2"	11	56	25
T375	3 3/4"	3 5/8"	11	57	25
T387	3 7/8"	3 3/4"	11	57	25

FINISH: Electro-Galvanized(EZN), other finishes available upon request.

Part Number	O.D. Size	Tube Size	Steel Ga.	Wt. 100Pcs	Std. Pkg.
T400	4"	3 7/8"	11	61	25
T412	4 1/8"	4"	11	61	25
T425	4 1/4"	4 1/8"	11	64	25
T437	4 3/8"	4 1/4"	11	64	25
T450	4 1/2"	4 3/8"	11	66	25
T462	4 5/8"	4 1/2"	11	66	25
T475	4 3/4"	4 5/8"	11	68	25
T487	4 7/8"	4 3/4"	11	73	25
T500	5"	4 7/8"	11	74	25
T512	5 1/8"	5"	11	70	25
T525	5 1/4"	5 1/8"	11	70	25
T537	5 3/8"	5 1/4"	11	77	25
T550	5 1/2"	5 3/8"	11	78	25
T562	5 5/8"	5 1/2"	10	83	25
T575	5 3/4"	5 5/8"	10	84	25
T587	5 7/8"	5 3/4"	10	85	25
T600	6"	5 7/8"	10	94	25
T612	6 1/8"	6"	10	94	25
T625	6 1/4"	6 1/8"	10	96	25
T637	6 3/8"	6 1/4"	10	98	25
T650	6 1/2"	6 3/8"	10	99	25
T662	6 5/8"	6 1/2"	10	100	25
T675	6 3/4"	6 5/8"	10	102	25
T687	6 7/8"	6 3/4"	10	104	Bulk
T700	7"	6 7/8"	10	108	Bulk
T712	7 1/8"	7"	10	108	Bulk
T737	7 3/8"	7 1/8"	10	112	Bulk
T762	7 5/8"	7 3/8"	10	115	Bulk
T787	7 7/8"	7 5/8"	10	119	Bulk
T800	8"	7 7/8"	10	121	Bulk

TUBING CLAMPS

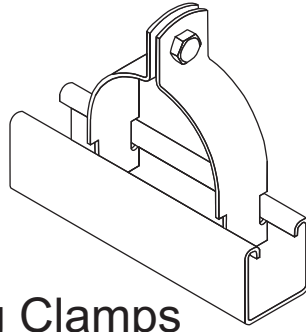

Copper Tubing Clamps

Part Number	O.D. Size	Tube Size	Steel Ga.	Wt. 100Pcs	Std. Pkg.
T025CPAS	3/8	1/4	16	9	100
T037CPAS	1/2	3/8	16	9	100
T050CPAS	5/8	1/2	16	10	100
T062CPAS	3/4	5/8	16	11	100
T075CPAS	7/8	3/4	16	12	100
T100CPAS	1-1/8	1"	16	15	100
T125CPAS	1-3/8	1-1/4	14	18	100
T150CPAS	1-5/8	1-1/2	14	22	50
T200CPAS	2-1/8	2"	12	32	50
T250CPAS	2-5/8	2-1/2	12	36	50
T300CPAS	3-1/8	3"	12	39	50
T350CPAS	3-5/8	3-1/2	12	46	50
T400CPAS	4-1/8	4"	11	48	25
T500CPAS	5-1/8	5"	11	73	25
T600CPAS	6-1/8	6"	10	92	25
T800CPAS	8-1/8	8"	10	121	BULK

FINISH: Copper plated

CUSHION CLAMPS

Cushion Features

- Reduces noise due to shock and vibration
- Eliminates metal to metal contact
- Usable temperatures from +275° F to -65° F
- Fast and easy installation
- Permits various fluid conductors to be mixed.
- Resists most fuels, oil, gases, solvents
- Manufactured from a thermoplastic elastomer material

Clamp Features

- Fits all standard 1-5/8 channel
- Features a unique shoulder stud which is securely fastened to one half of the clamp (available up to 1-3/8 clamp). This eliminates over-tightening and rotation.
- A nylon-insert nut assuring a positive lock
- Zinc Dichromate, also available in stainless

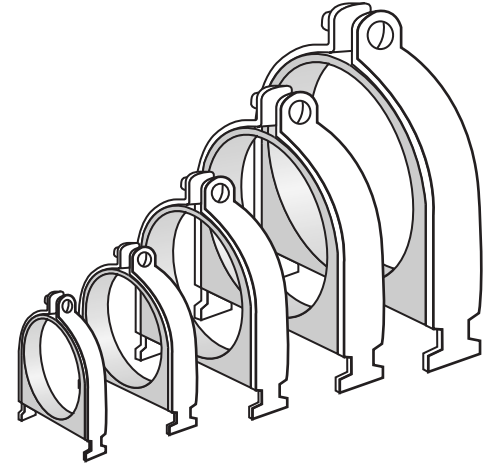

Cushion Clamps for Tube

Part Number	Tube O.D. Size	Steel Ga.	Wt/ 100Pcs.	Std. Pkg.
CCT025	1/4	14	12	24
CCT037	3/8	14	12	24
CCT050	1/2	14	16	24
CCT062	5/8	14	16	24
CCT075	3/4	14	20	24
CCT087	7/8	14	20	24
CCT100	1"	12	24	12
CCT112	1-1/8	12	30	12
CCT125	1-1/4	12	30	12
CCT137	1-3/8	11	30	12
CCT150	1-1/2	11	30	12
CCT162	1-5/8	11	40	12
CCT175	1-3/4	11	40	12
CCT187	1-7/8	11	40	12
CCT200	2"	11	46	12
CCT212	2-1/8	11	50	BULK
CCT225	2-1/4	11	50	BULK
CCT250	2-1/2	11	56	BULK
CCT262	2-5/8	11	58	BULK
CCT300	3"	11	60	BULK
CCT312	3-1/8	11	62	BULK
CCT362	3-5/8	11	76	BULK
CCT400	4"	11	80	BULK
CCT412	4-1/8	11	100	BULK
CCT612	6-1/8	11	170	BULK

CUSHION CLAMPS

Cushion Features

- Reduces noise due to shock and vibration
- Eliminates metal to metal contact
- Usable temperatures from +275°F to -65°F
- Fast and easy installation
- Permits various fluid conductors to be mixed.
- Resists most fuels, oil, gases, solvents
- Manufactured from a thermoplastic elastomer material

Clamp Features

- Fits all standard 1-5/8 channel
- Features a unique shoulder stud which is securely fastened to one half of the clamp (available up to 1-3/8 clamp). This eliminates over-tightening and rotation.
- A nylon-insert nut assuring a positive lock
- Zinc Dichromate, also available in stainless

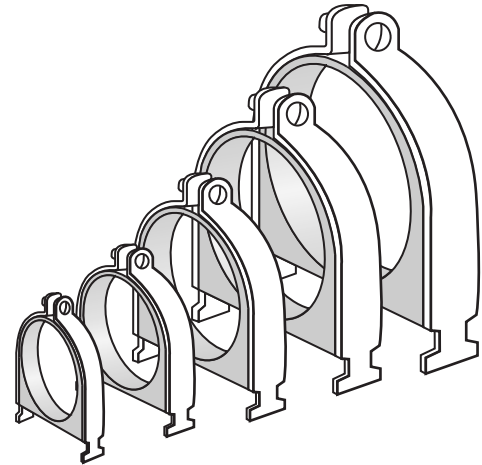

Cushion Clamps for Pipe

Part Number	Pipe Size	Steel Ga.	Wt./ 100Pcs	Std. Pkg.
CCP025	1/4	14	12	24
CCP037	3/8	14	14	24
CCP050	1/2	14	22	24
CCP075	3/4	12	58	24
CCP100	1"	11	39	12
CCP125	1-1/4	11	43	12
CCP150	1-1/2	11	47	12
CCP200	2"	11	55	12
CCP250	2-1/2	12	60	12
CCP300	3"	11	76	12
CCP350	3-1/2	11	94	12
CCP400	4"	11	93	12
CCP500	5"	11	125	BULK
CCP600	6"	11	145	BULK

Cushion Strip also available in 25 ft rolls

FLAT FITTINGS

Square Washer

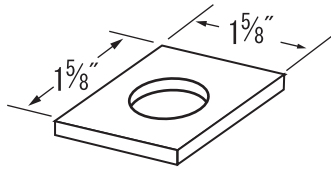

Part Number	Bolt Size	Wt./ 100Pcs.
D200	5/16	18
D201	3/8	18
D202	1/2	17
D202-1	5/8	16
D202-2	3/4	15

Guided Square Washer

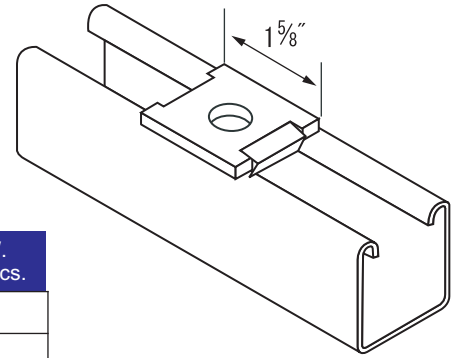

Part Number	Bolt Size	Wt./ 100Pcs.
D200D	1/4	18
D201D	3/8	18
D202D	1/2	17

D528 Flat Plate Connector

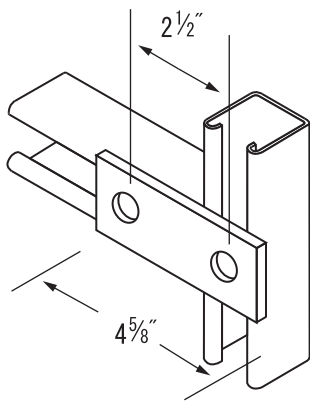

Wt.50#/C

D129 Two Hole Splice Plate

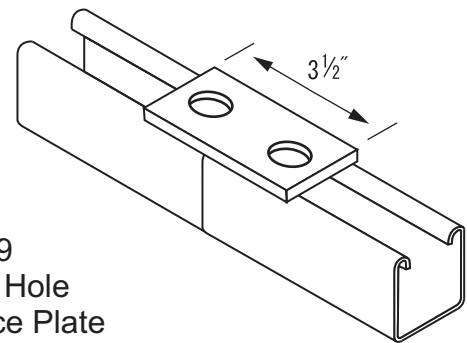

Wt.35#/C

D340 Splice Plate

Wt.34#/C

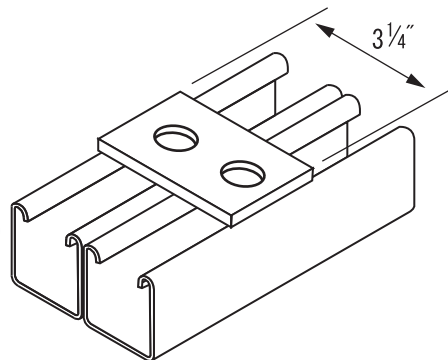

DATA: 1/4 thick, 1-5/8 wide, holes 9/16 dia., spaced 1-7/8 on center and 13/16 from end.
FINISH: Electrogalvanized
Also available in stainless, powder coat and HDG.

D557 Three Hole Splice Plate

Wt.50#/C

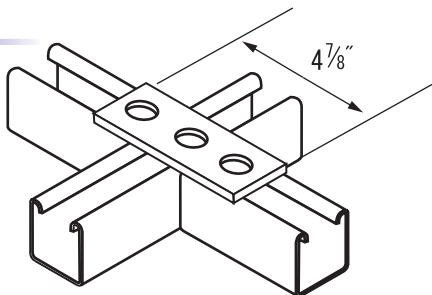

D141 Three Hole Splice Plate

Wt.55#/C

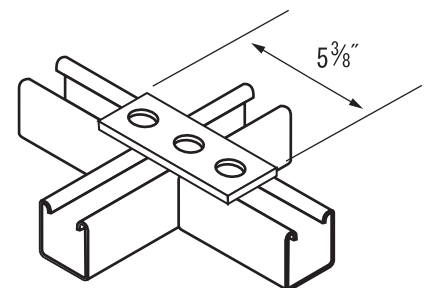

FLAT FITTINGS

D341
Four Hole
Splice Plate

Wt. 76#/C

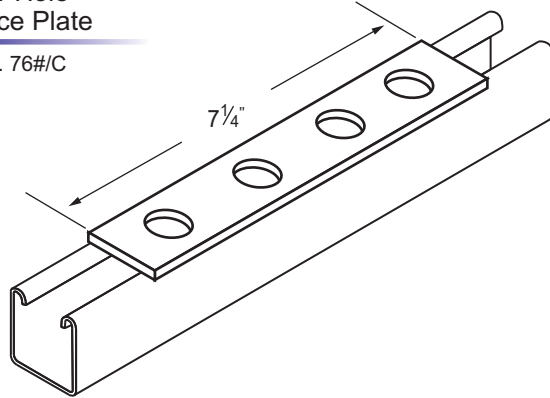

D133
Four Hole
Tee Plate

Wt. 75#/C

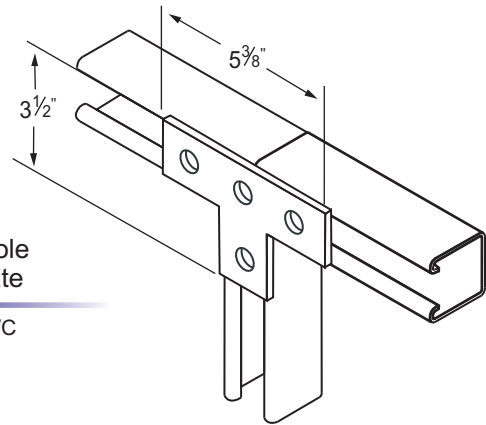

D140
Three Hole
Flat Angle Plate

Wt. 56#/C

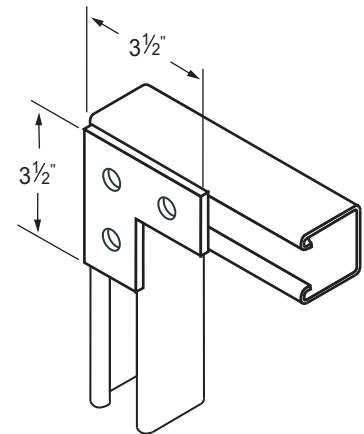

DATA: 1/4 thick, 1-5/8 wide, holes 9/16 dia., spaced 1-7/8 on center and 13/16 from end.
FINISH: Electrogalvanized
Also available in stainless, powder coat and HDG.

D143
Four Hole
Corner Plate

Wt. 75#/C

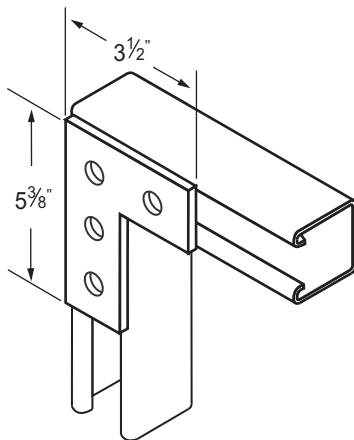

D132
Cross Plate

Wt. 100#/C

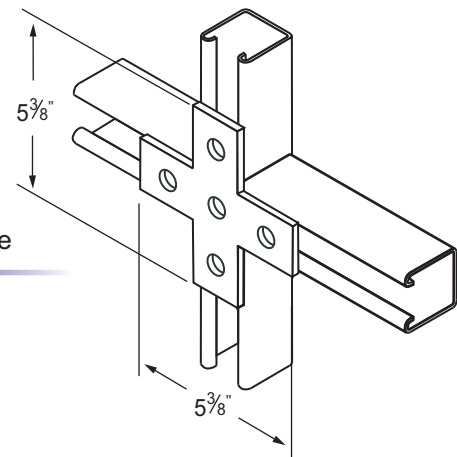

FLAT FITTINGS

D135
Three Hole Corner
Connector

Wt.70#/C

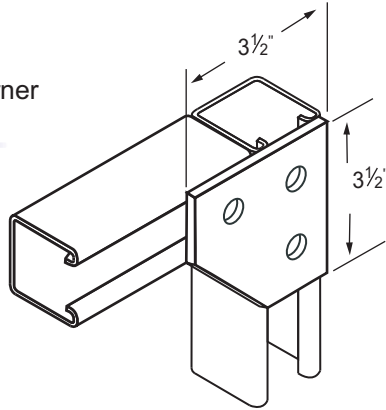

D337
Three Hole
Connection Plate

Wt.70#/C

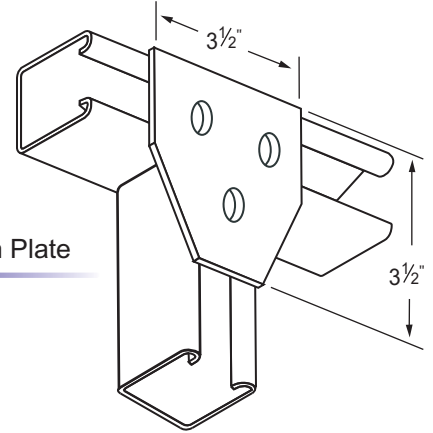

D136
Four Hole
Connector

Wt.100#/C

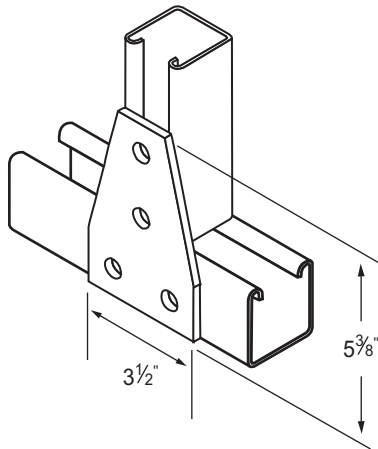

D142
Four Hole
Corner
Connector

Wt.102#/C

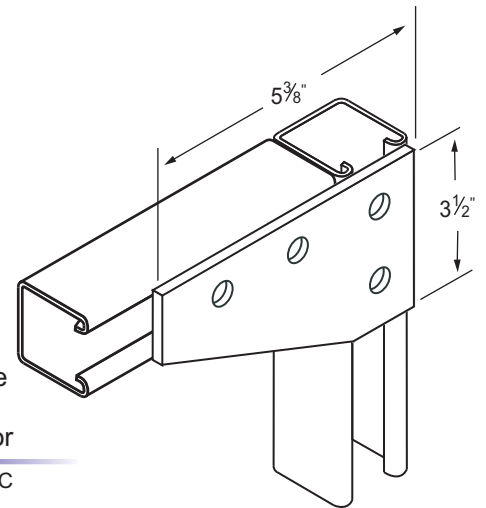

D556
Flat Corner
Connector

Wt.150#/C

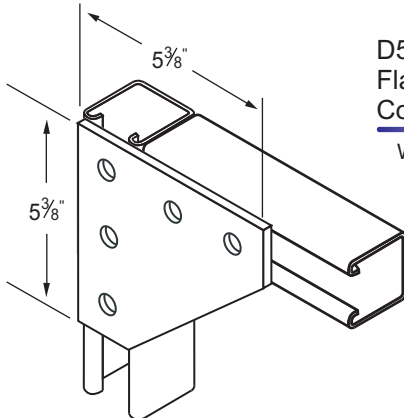

DATA: 1/4 thick, 1-5/8 wide, holes 9/16 dia., spaced 1-7/8 on center and 13/16 from end.
FINISH: Electrogalvanized
Also available in stainless, powder coat and HDG.

D532
Five Hole
Connector

Wt.143#/C

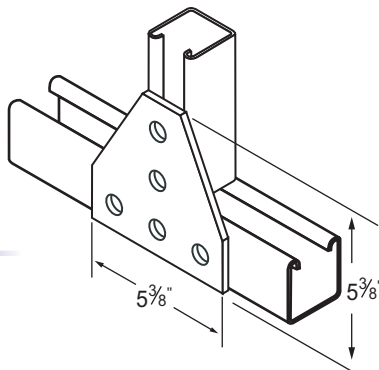

D334
Seven Hole
Connector

Wt.232#/C

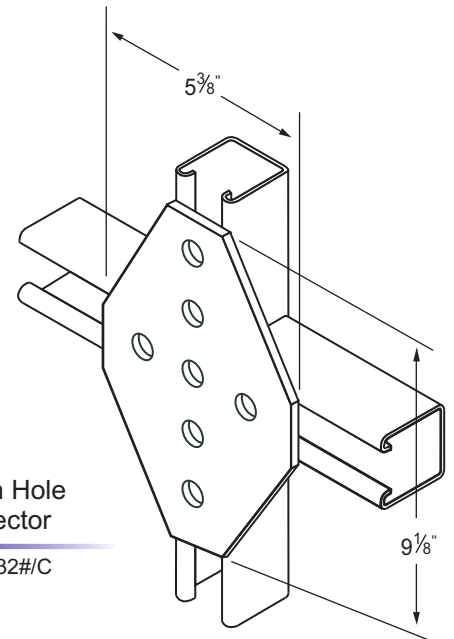

ANGLE FITTINGS

D101
Two Hole
Corner Angle
Wt.37#/C

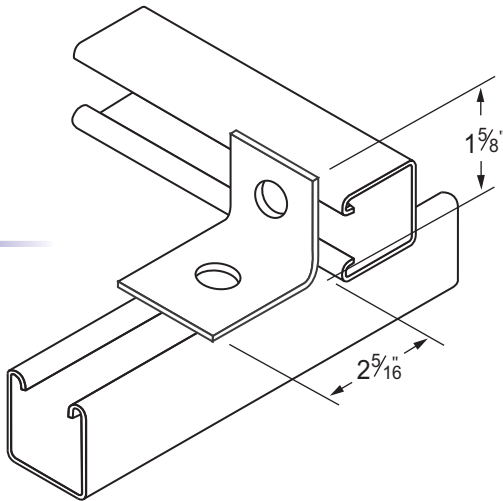

D230
Connection
Angle
Wt.37#/C

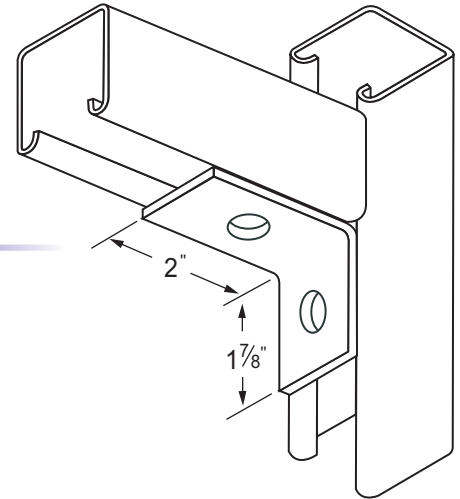

D104
Four Hole Angle
Wt.78#/C

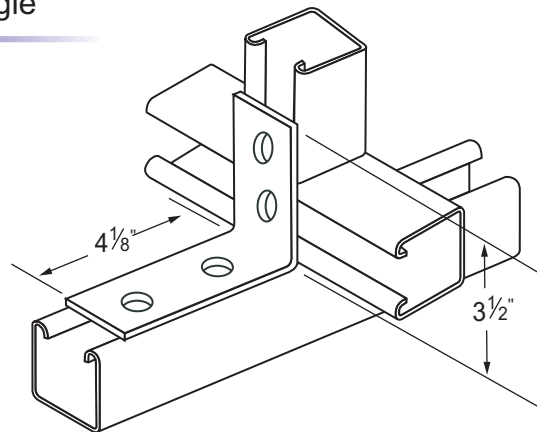

DATA: 1/4 thick, 1-5/8 wide, holes 9/16 dia., spaced 1-7/8 on center and 13/16 from end.
FINISH: Electrogalvanized
Also available in stainless, powder coat and HDG.

D102
Three Hole
90° Bracket
Wt.57#/C

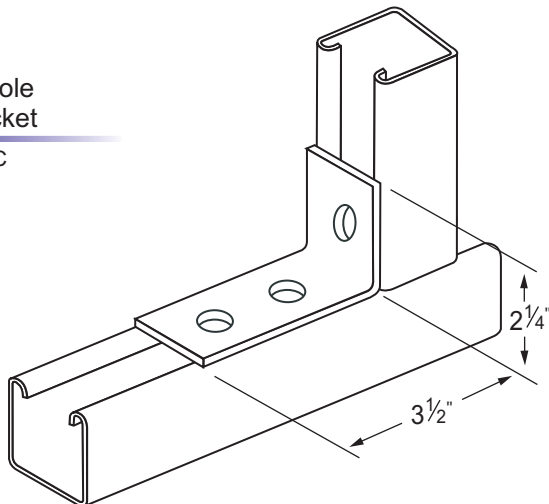

D103
Three Hole
Corner
Connector
Wt.56#/C

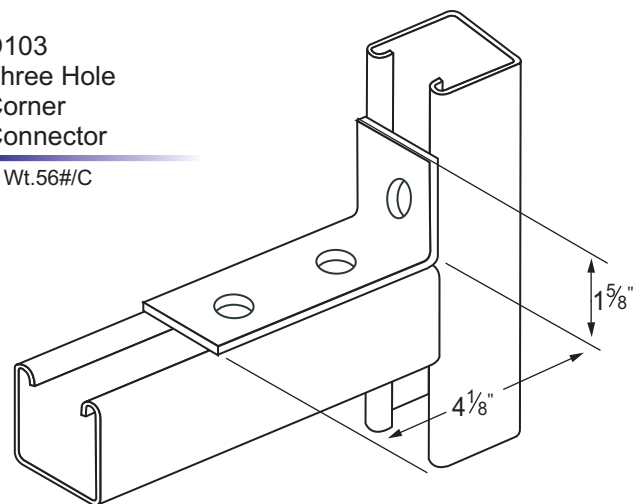

ANGLE FITTINGS

D118
Four Hole
Joint
Connector

Wt.102#/C

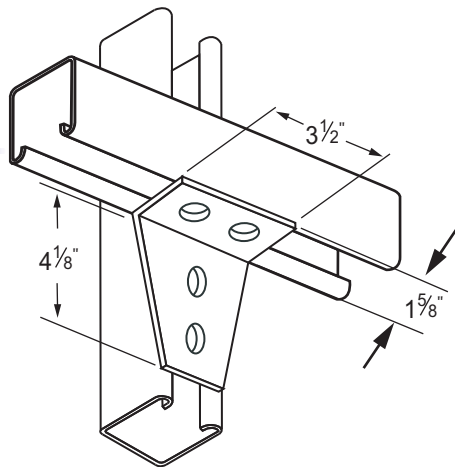

D126
Four Hole
Duplex
Corner Angle

Wt.101#/C

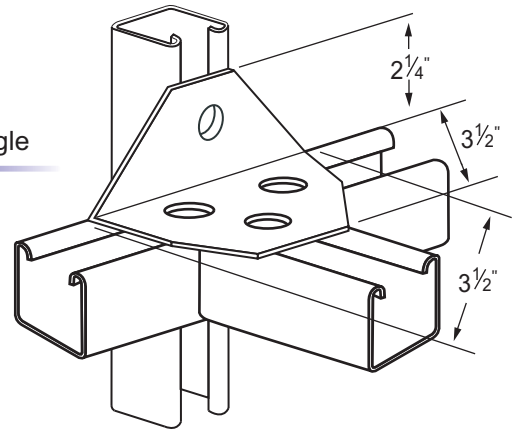

DATA: 1/4 thick, 1-5/8 wide, holes 9/16 dia., spaced 1-7/8 on center and 13/16 from end.
FINISH: Electrogalvanized
Also available in stainless, powder coat and HDG.

D533
Five Hole Joint
Connector Angle

Wt.141#/C

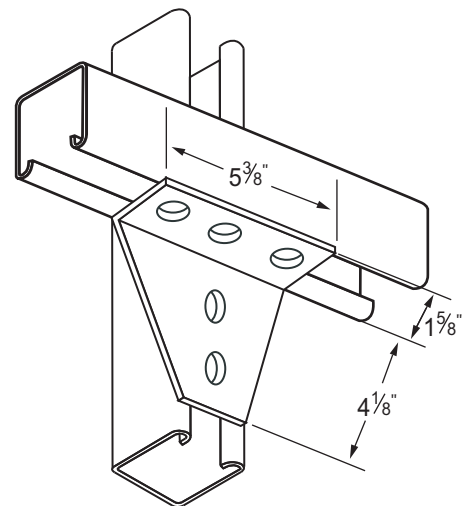

Slotted Joint
Connector Angle

Part Number	"A"	"B"	Wt. 100Pcs.
D112	6-5/8	4"	180
D113	8-5/8	6"	256

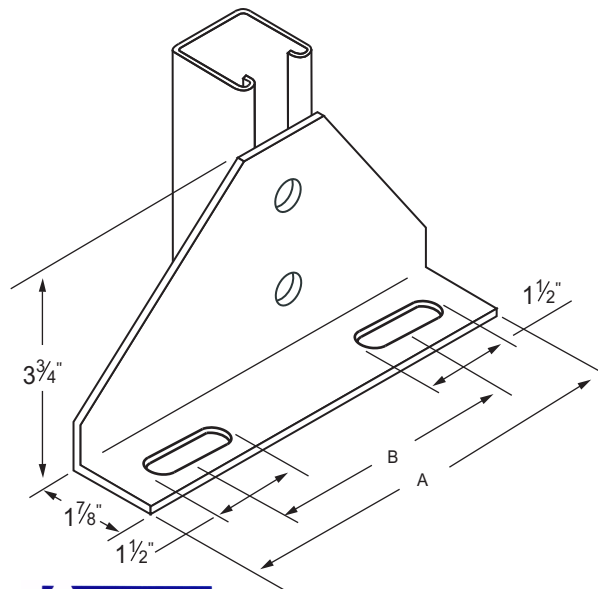

ANGLE FITTINGS

D154
Two Hole
Open 45° Angle

Wt.60#/C

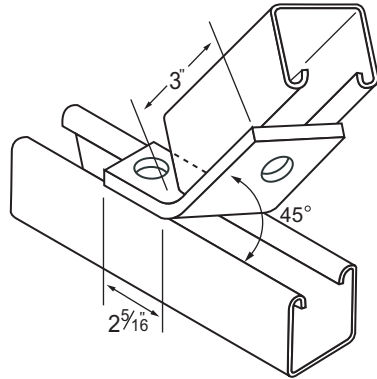

D155
Two Hole
Closed 45° Angle

Wt.63#/C

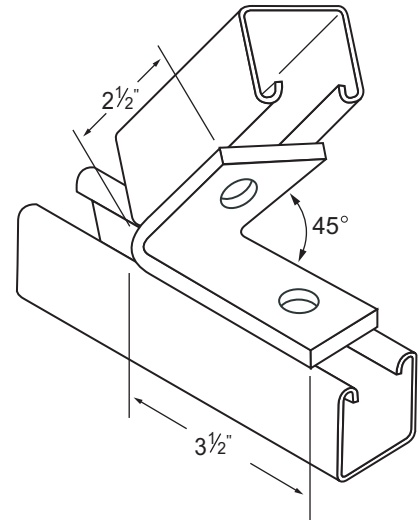

Angle Bracket

Wt.63#/C

Part Number	"A"
D147	82-1/2°
D148	75°
D149	67-1/2°
D150	60°
D151	52-1/2°
D152	37-1/2°

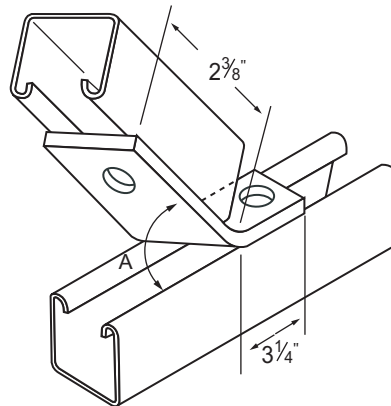

DATA: 1/4 thick, 1-5/8 wide, holes 9/16 dia., spaced 1-7/8 on center and 13/16 from end.
FINISH: Electrogalvanized
Also available in stainless, powder coat and HDG.

Four Hole Open Angle Bracket

Wt.78#/C

Part Number	"A"
D243	7-1/2°
D244	15°
D245	22-1/2°
D246	30°
D247	37-1/2°
D248	45°
D249	52-1/2°
D250	60°
D251	67-1/2°
D252	75°
D253	82-1/2°

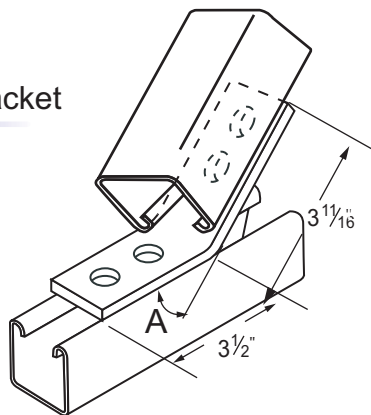

Two Hole Open Angle Bracket

Wt.59#/C

Part Number	"A"
D162	30°
D163	22-1/2°
D164	15°
D165	7-1/2°

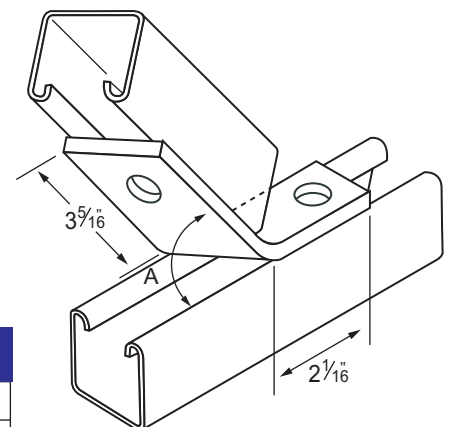

ANGLE FITTINGS

D372 Slotted Angle

Wt.38#/C

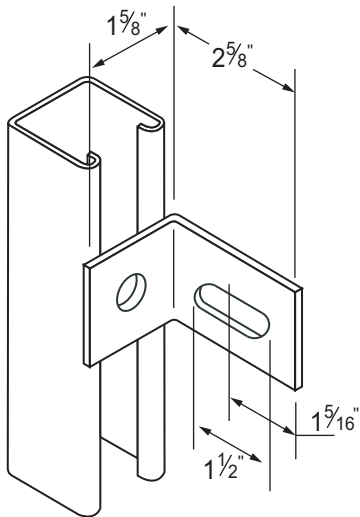

Two Hole Offset Angle

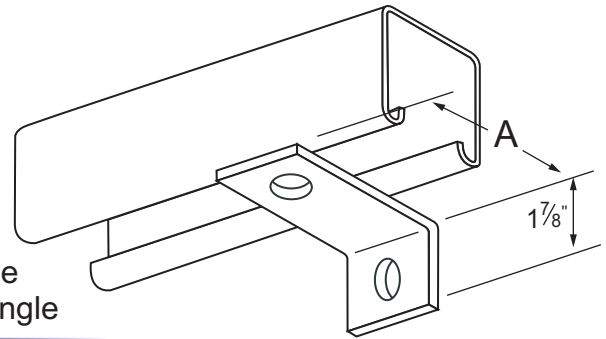

Part Number	"A"	Wt./ 100Pcs.
D359	3"	48
D360	3-1/2"	53
D361	4"	60

DATA: 1/4 thick, 1-5/8 wide, holes 9/16 dia., spaced 1-7/8 on center and 13/16 from end.
FINISH: Electrogalvanized
Also available in stainless, powder coat and HDG.

D371-2 Two Hole Slotted 90° Corner Angle

Wt.66#/C

Four Hole Closed Angle Bracket

Wt.100#/C

Part Number	"A"
D363	82 1/2°
D364	75°
D365	67 1/2°
D366	60°
D367	52 1/2°
D368	45°
D369	37 1/2°

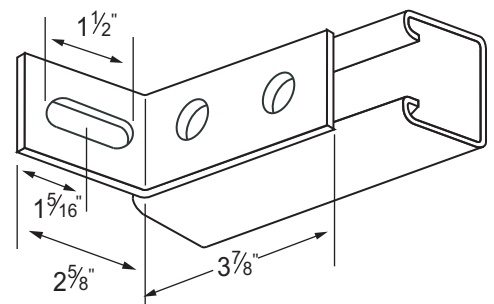
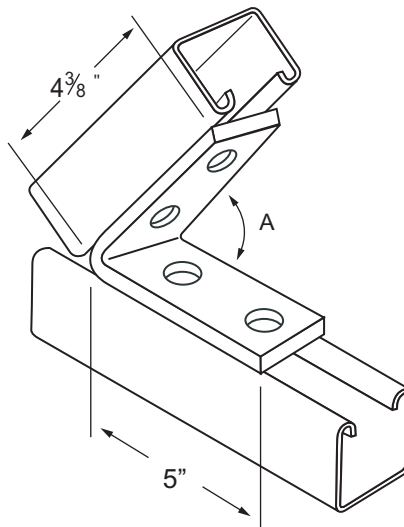

ANGLE FITTINGS

D231
No-Twist
Corner Angle
Two Indent

Wt.39#/C

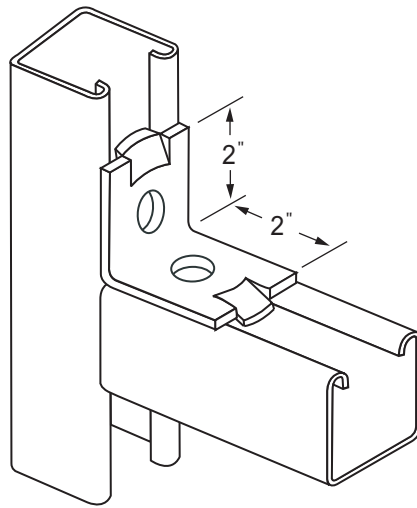

D357
Four Hole 90°
T-Plate Angle

Wt.77#/C

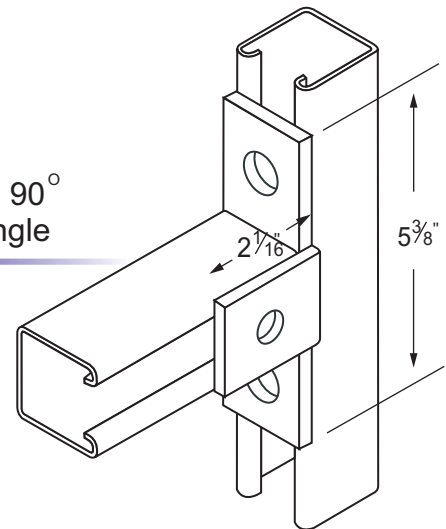

DATA: 1/4 thick, 1-5/8 wide, holes 9/16 dia., spaced 1-7/8 on center and 13/16 from end.
FINISH: Electrogalvanized
Also available in stainless, powder coat and HDG.

D844
Universal Shelf
Bracket

Wt.132#/C

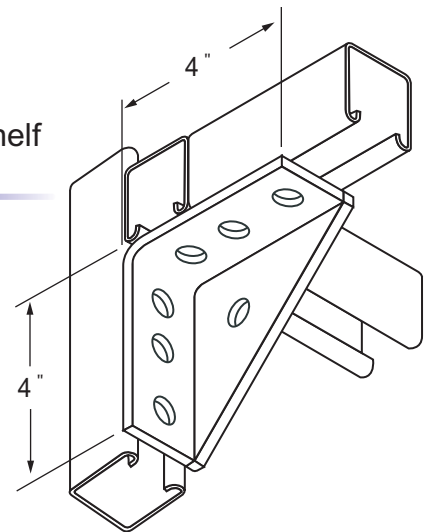

D236R or D236L
Three Hole
90° Angle
(right angle shown)

Wt.54#/C

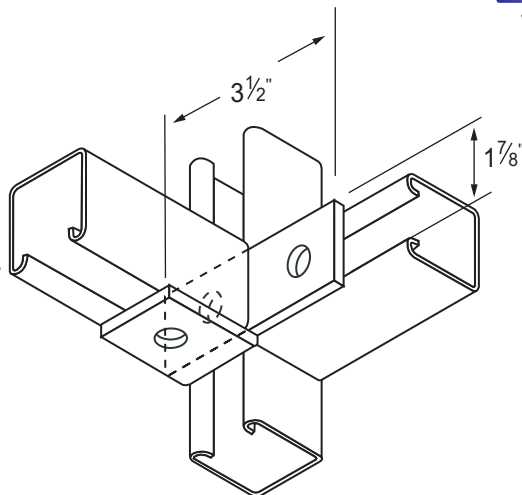

WING FITTINGS

B267L - B267R
Three Hole Single
Angle Connector
 (right angle shown)

Wt.60#/C

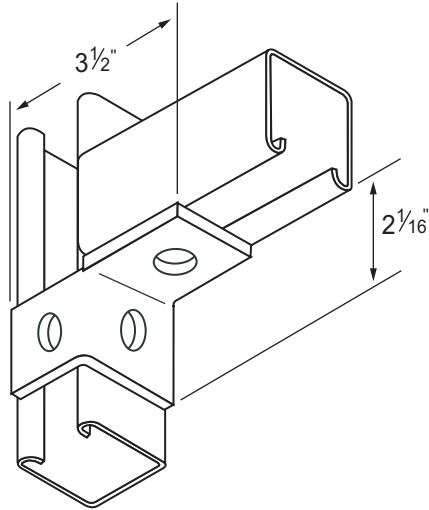

D269L - D269R
Six Hole Single
Angle Connector
 (right angle shown)

Wt.119#/C

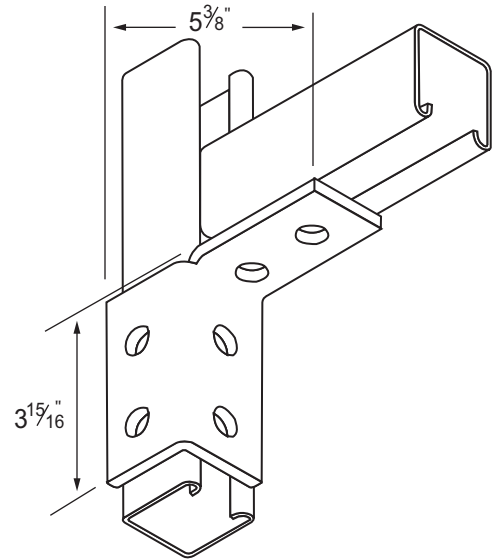

D119
Four Hole Double
Angle Connector

Wt.76#/C

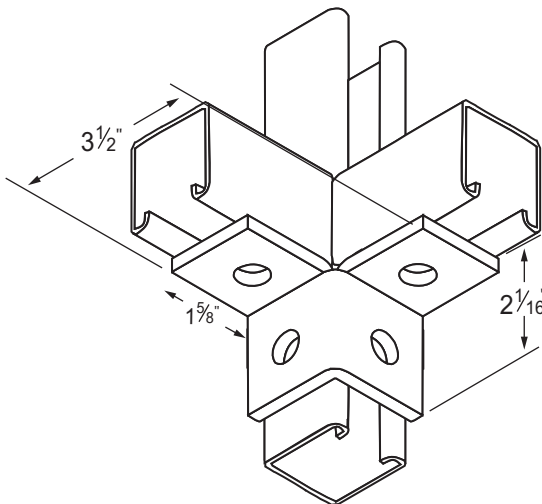

DATA: 1/4 thick, 1-5/8 wide, holes 9/16 dia., spaced 1-7/8 on center and 13/16 from end.
 FINISH: Electrogalvanized
 Also available in stainless, powder coat and HDG.

D121
Eight Hole Double
Angle Connector

Wt.155#/C

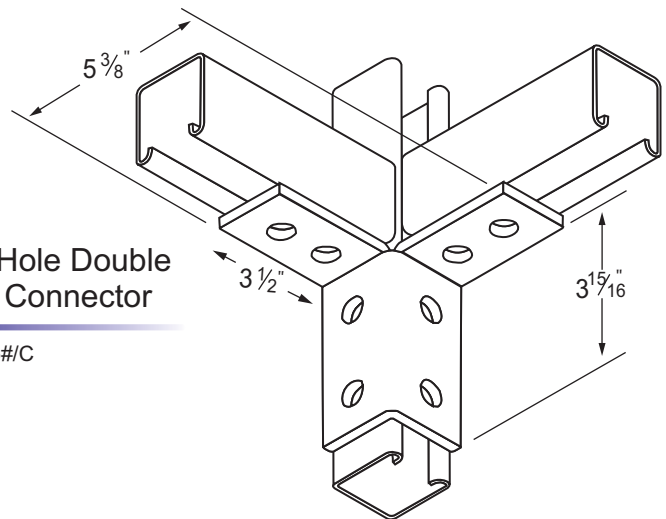

WING FITTINGS

D271
Five Hole Double
Wing Connector

Wt.93#/C

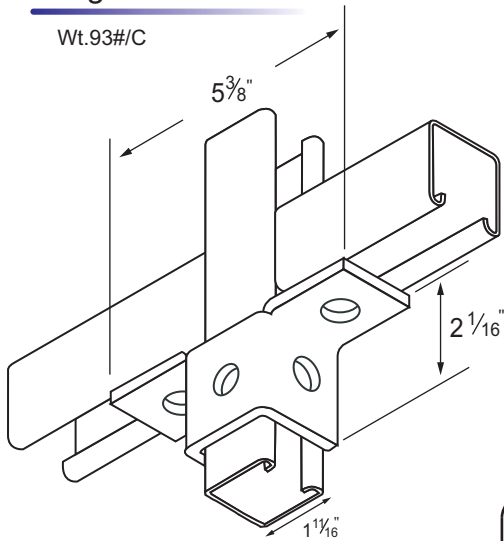

D273
Ten Hole Double
Wing Connector

Wt.193#/C

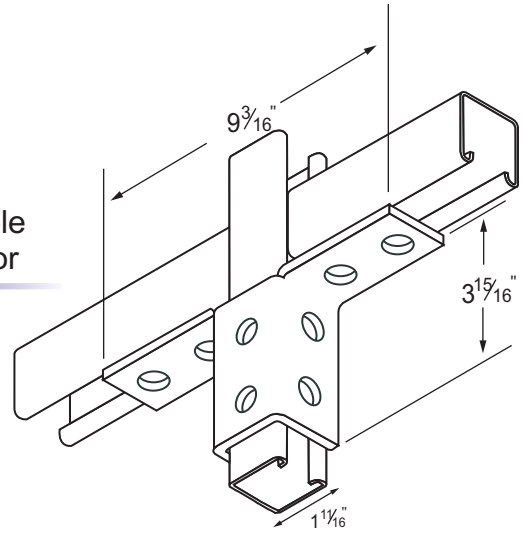

DATA: 1/4 thick, 1-5/8 wide, holes 9/16 dia., spaced 1-7/8 on center and 13/16 from end.
FINISH: Electrogalvanized
Also available in stainless, powder coat and HDG.

D122
Six Hole Triple
Wing Connector

Wt.113#/C

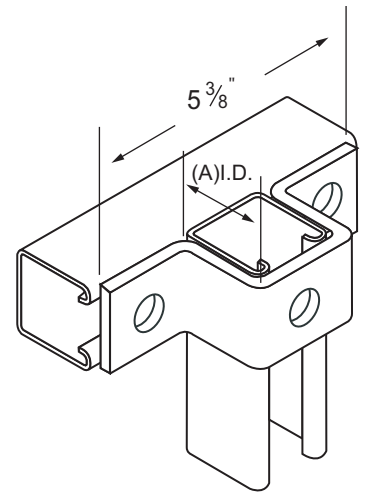
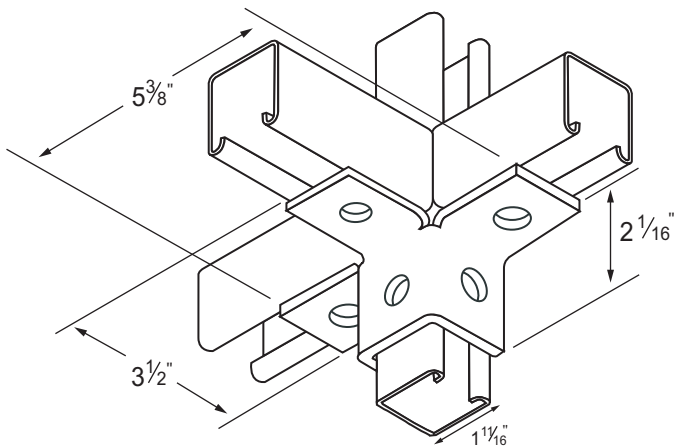

U-Support

Part Number	"A"	Wt./ 100Pcs.
D107	1-5/8	85
D107-22A	3-1/4	126

POST BASES

D279SQ Single Post Base

Wt.314#/C

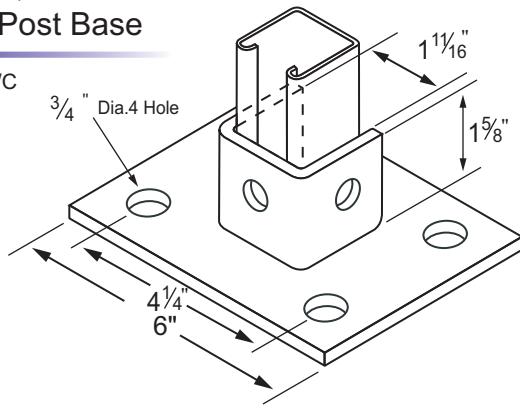

DATA: 1/4 thick, 1-5/8 wide, holes 9/16 dia., spaced 1-7/8 on center and 13/16 from end.

FINISH:
Electrogalvanized
Also available in stainless, powder coat and HDG.

D281ASQ Double Post Base

Wt.330#/C

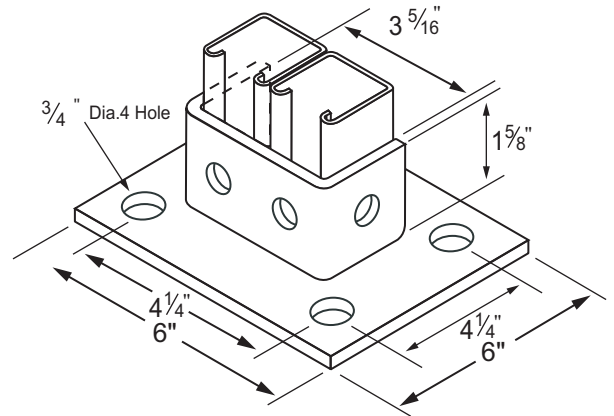

D280SQ Single Post Base

Wt.392#/C

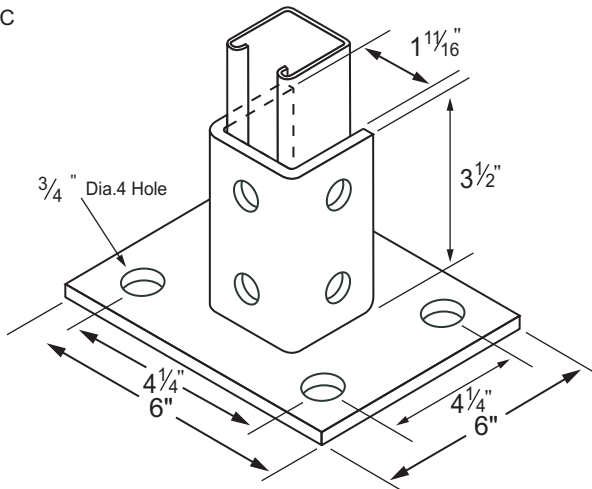

D281SQ Double Post Base

Wt.408#/C

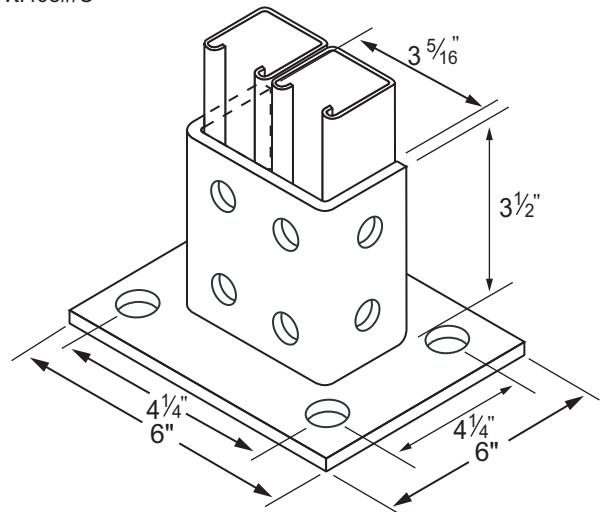

D278 Corner Post Base

Wt.297#/C

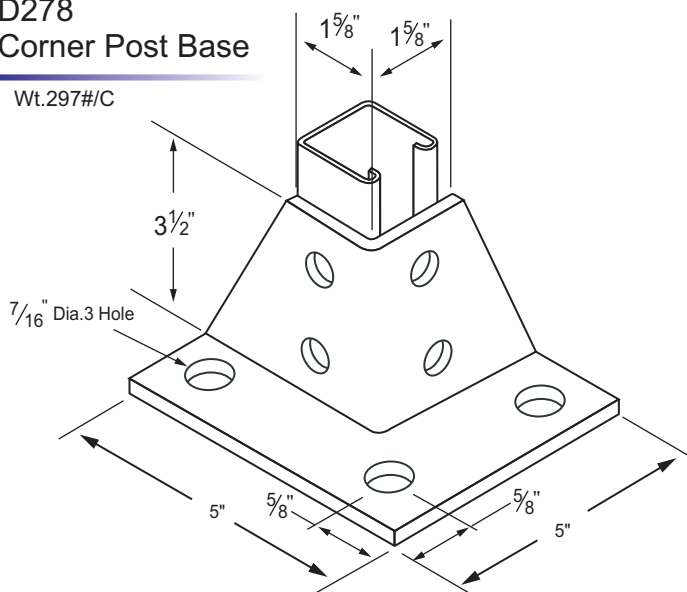

POST BASES

D279FL Double Post Base

Wt.230#/C

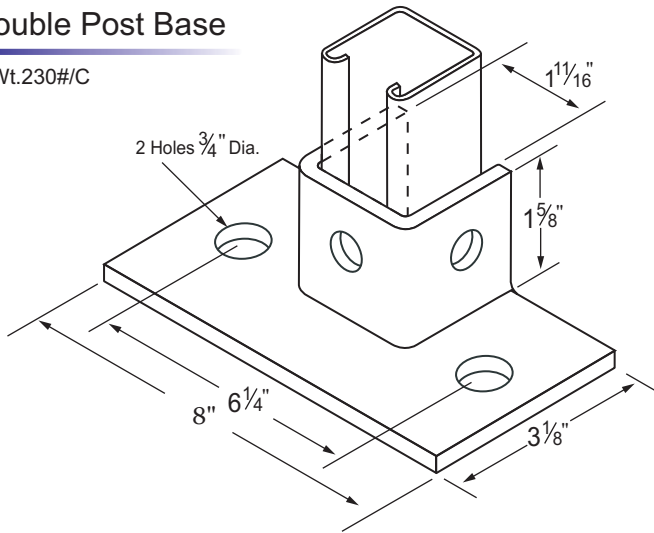

DATA: 1/4 thick, 1-5/8 wide, holes 9/16 dia., spaced 1-7/8 on center and 13/16 from end.

FINISH:
Electrogalvanized
Also available in stainless, powder coat and HDG.

D281AFL Double Post Base

Wt.250#/C

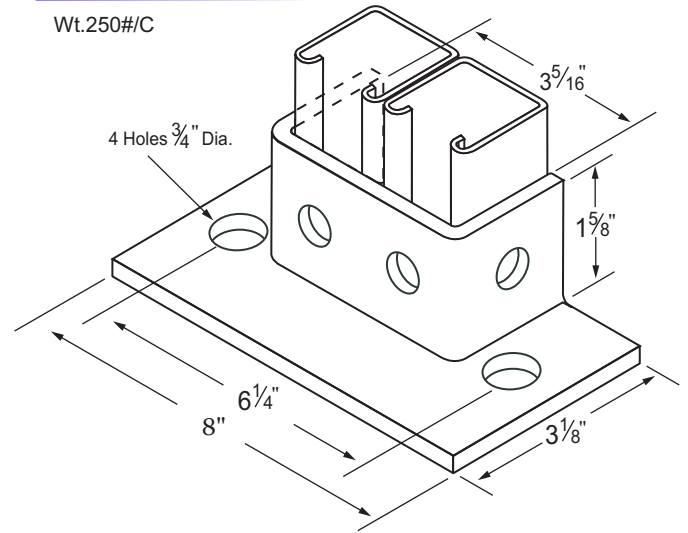

D281FL Double Post Base

Wt.320#/C

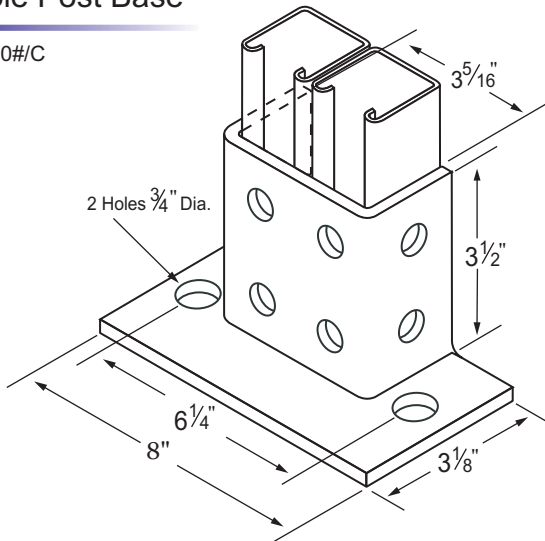

D280FL Double Post Base

Wt.312#/C

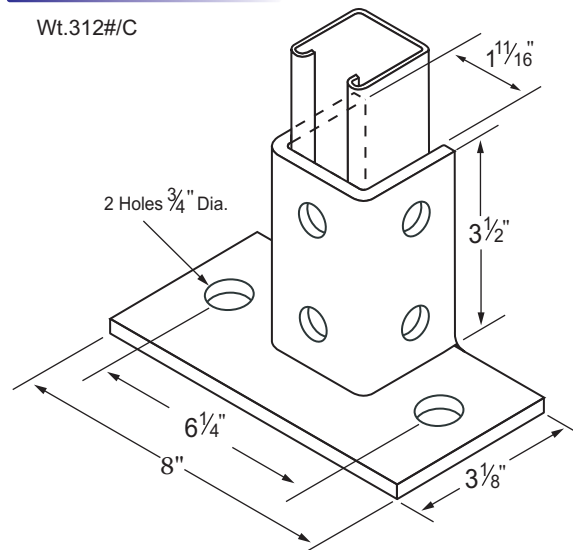

POST BASES

D279
Single Post Base

Wt.307#/C

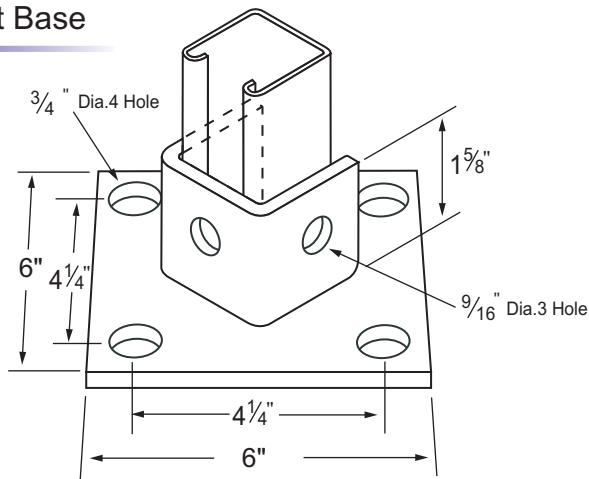

D281A
Double Post Base

Wt.325#/C

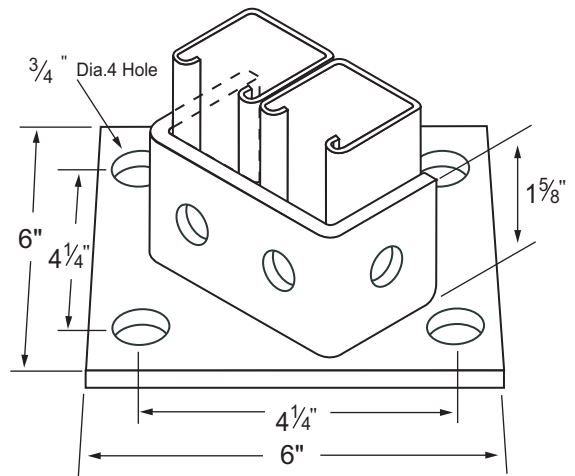

DATA: 1/4 thick, 1-5/8 wide, holes 9/16 dia., spaced 1-7/8 on center and 13/16 from end.
FINISH: Electrogalvanized
Also available in stainless, powder coat and HDG.

D280
Single Post Base

Wt.373#/C

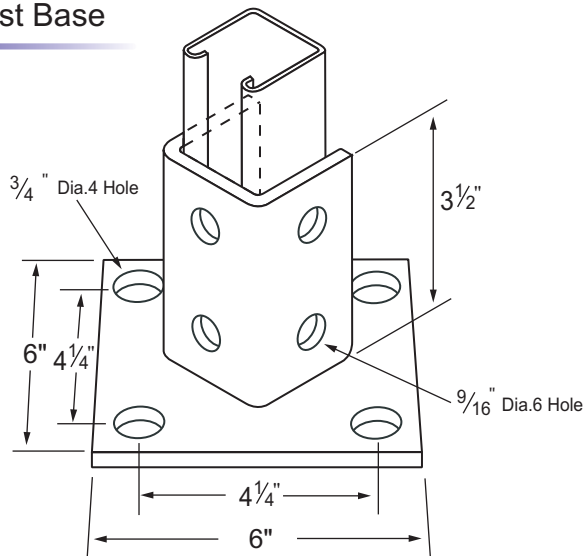

D281
Double Post Base

Wt.408#/C

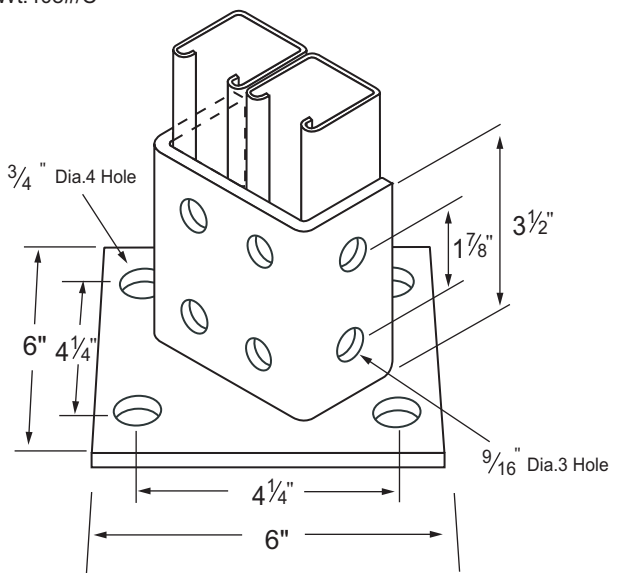

SPLICE CHANNEL

D169
Two Hole
Splice Channel
13/16

Wt.84#/C

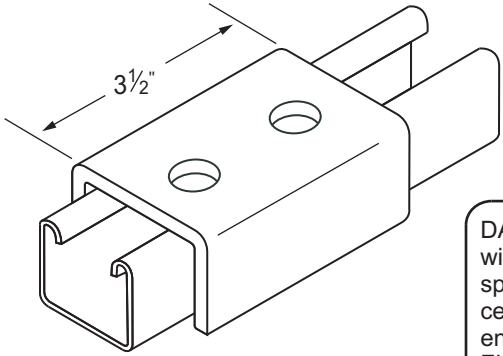

D170
Two Hole
Splice Channel
1-5/8

Wt.123#/C

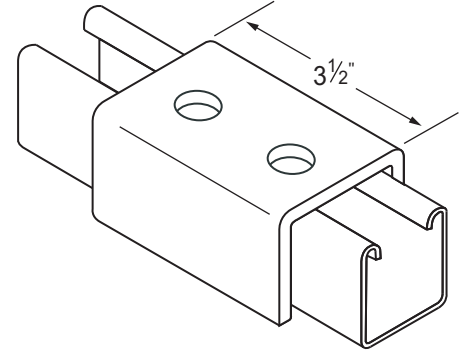

D168
Three Hole
Splice Channel
13/16

Wt.126#/C

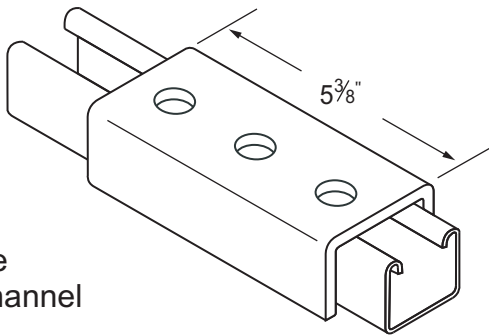

DATA: 1/4 thick, 1-5/8 wide, holes 9/16 dia., spaced 1-7/8 on center and 13/16 from end.
FINISH: Electrogalvanized Also available in stainless, powder coat and HDG.

D171
Three Hole
Splice Channel
1-5/8

Wt.195#/C

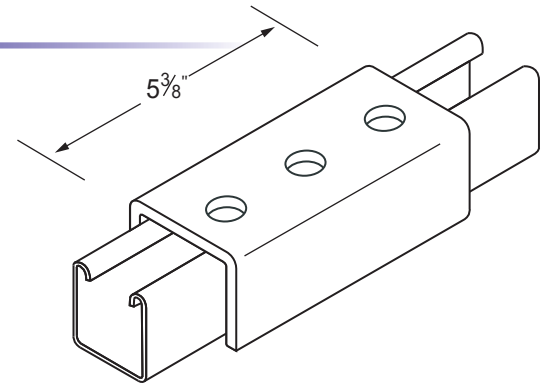

D167
Four Hole
Splice Channel
13/16

Wt.178#/C

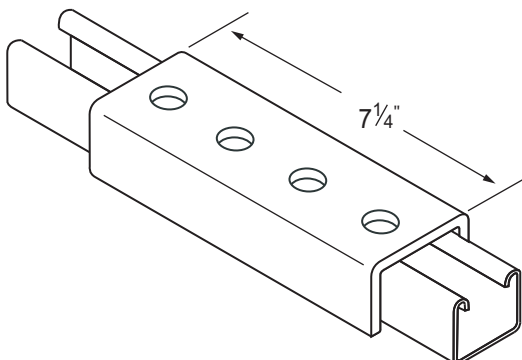

D172
Four Hole
Splice Channel
1-5/8

Wt.266#/C

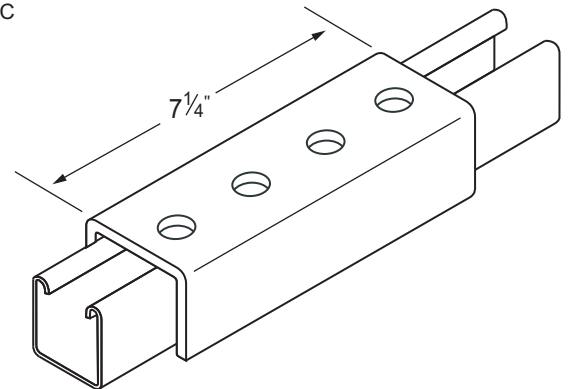

GENERAL FITTINGS

Knee Brace

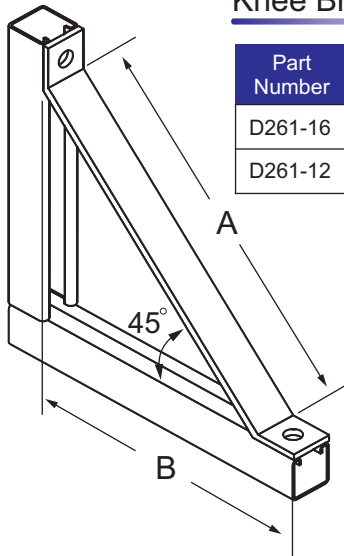

Part Number	"A"	"B"	Wt./ 100Pcs
D261-16	16-5/8	13-3/8	218
D261-12	12"	10-1/8	165

DATA: 1/4 thick, 1-5/8 wide, holes 9/16 dia., spaced 1-7/8 on center and 13/16 from end.
FINISH: Electrogalvanized
Also available in stainless, powder coat and HDG.

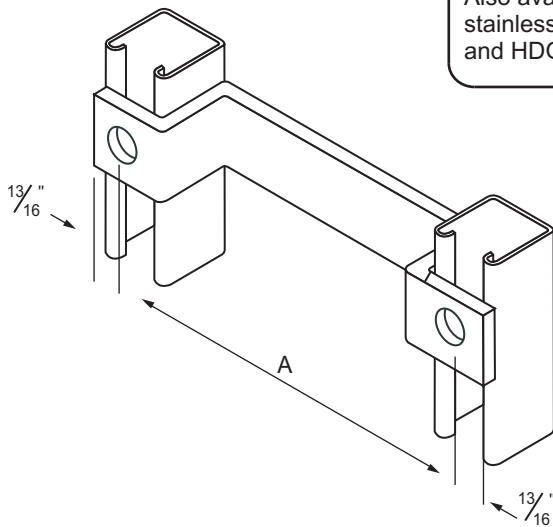

Ladder Rung

Part Number	"A"	Wt./ 100Pcs
D411-12	12"	176
D411-15	15"	202
D411-18	18"	234

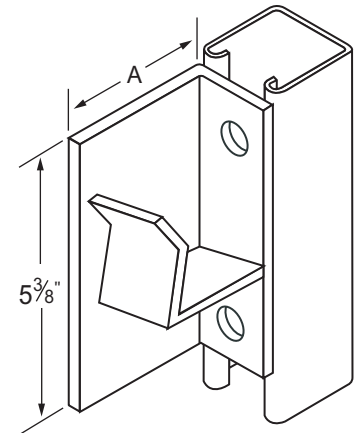

L/R Support

Part Number	"A"	Wt./ 100Pcs
D214L	3"	200
D214R	3"	200
D514L	3-5/8	246
D514R	3-5/8	246

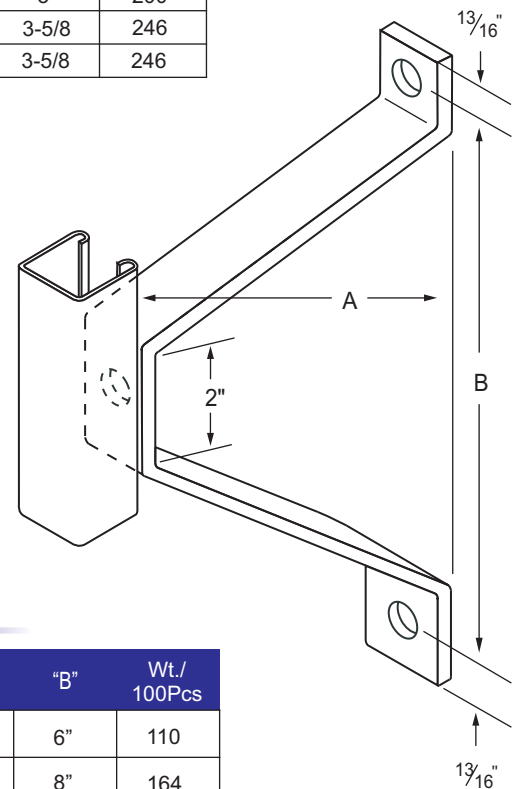

Wall Bracket

Part Number	"A"	"B"	Wt./ 100Pcs
D381	2-3/8	6"	110
D382	4-3/8	8"	164
D383	6-3/8	10"	200
D384	6-3/8	12"	253
D385	6-3/8	14"	318

THREADED FASTENERS

WASHERS

Lock Washers
Flat Washers
Fender Washers

SCREWS

Hex Cap Screws
Machine Screws
Sheet Metal Screws
Grounding Screws
Self-Drilling Screws

NUTS

Hex Nuts
Heavy Hex Nuts
Square Nuts
Coupling Nuts
Locknuts

ANCHORS

Toggle Bolts
Plastic Anchor Kits
Zip-It Anchor Kits

MISC

Strut
Threaded Rod
Nylon Cable Ties
Cutting Tools
Bits

AVAILABLE IN PACKAGED AND BULK
PRIVATE LABELING AVAILABLE



STRUT SYSTEMS PACKAGED FASTENERS

Our commitment to Quality is ... *“Stainless”*

ISO 9001:2008 CERTIFIED

605 Springfield Rd.
Kenilworth, NJ 07033
Ph: (908) 688-2550 * Fax: (908) 688-9385

4785 Kirk Rd.
Winston - Salem, NC 27103
Ph: (336) 760-0050 * Fax: (336) 760-0580

Since 1980
divspec

www.divspec.com